

EVCS Type B Outstation

MAIN PROPERTIES

- Hands Free Operation
- Compact Design
- High Volume Ringer
- Flashing Status LED
- 20mm Cable Glands
- Braille Signage
- Duplex Speech
- Fully Monitored
- Stainless Steel Option

The VoCALL Emergency Voice Communications System (EVCS) is designed to fully comply with BS5839-Part 9:2003 (abb. Pt9) for use as a Fire Telephone system, Disabled Refuge Call system or as a combined system when both Fire Telephones and Disabled Refuge Points are required.

An EVCS is a fixed, secure, bi-directional, full duplex voice communication system to assist fire fighters in an emergency in high rise buildings or large sites where Radio communication may not work, and covers the operation of both fire telephones and disabled refuge systems. Where both systems are fitted to a building pt9 specifies these should form a single system.

FREQUENCY RESPONSE DIAGRAM

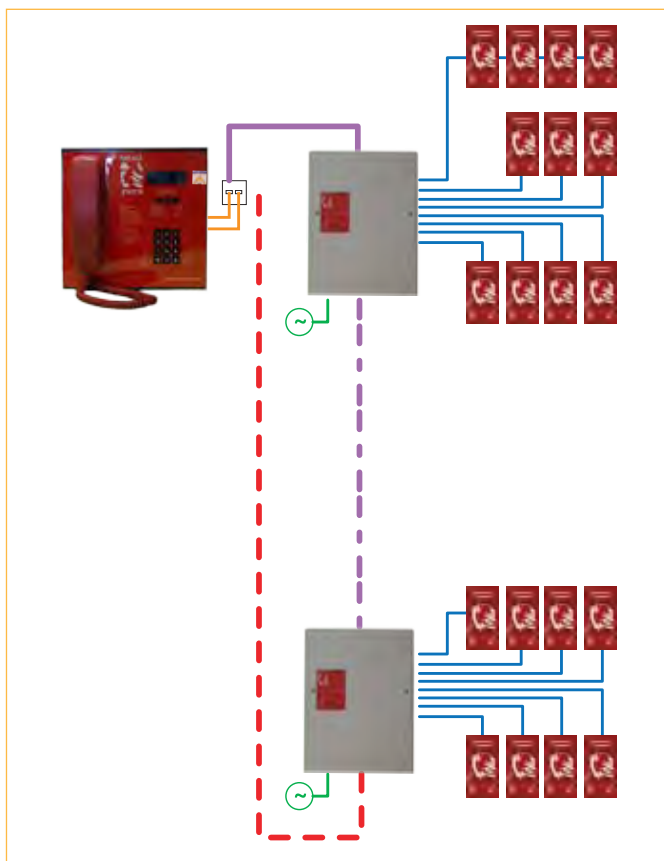

Fire Telephone VCSHF



FIRE MAN'S TELEPHONE - TELEPHONE

A VoCALL EVCS comprises of three functional blocks, the master handset (VCM) the eight line Exchanges (VCX-8) and outstations, (type A, type B or Jack points), with the quantities of these basic units being adjusted to suit the application.

The VCSHF is a Type B outstation as defined in BS5839-pt9, and can be used as a fire telephone or disabled refuge call point.

When choosing the outstation type for use with an EVCS we recommend reading Section 11 of BS5839-9:2003 which deals with outstation types, and states as follows:

11.1.2.a Type A should be used for evacuation or fire fighting use, and a type B unit should only be used where a type A is impractical

11.1.2.b For disabled refuges type A or type B can be used, however in Locations (section 11.6.2.i) type B outstations can only be used where the background noise is below 40dBA (therefore there can be no sounder or voice alarm coverage in the area)

The VoCALL outstations are designed for use by multi-disability users, having high contrast signage in line with RNIB guidelines and an induction loop coil (to BSEN60118-4) in the handset.

We recommend type A handsets in all locations, otherwise you may have to consider acoustic hoods or two outstations in each location for compliance with the other associated standards and laws, including BS8300 and the DDA (Disabilities Discrimination Act).

TECHNICAL SPECIFICATION

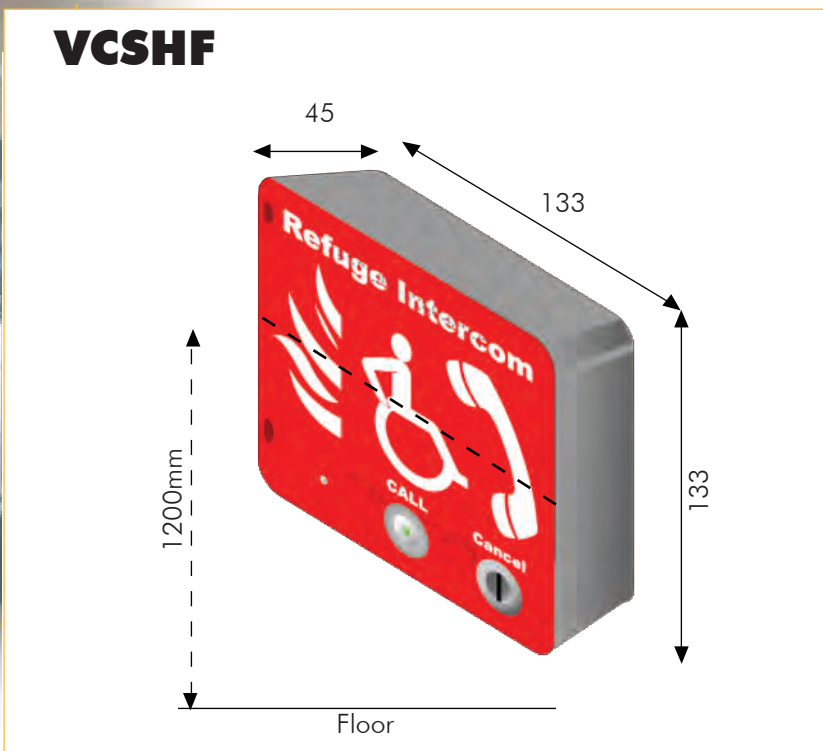

Mounting the Unit

The Handset should be mounted at a height of either 1200mm from the floor, or on a 1400mm centre line to comply with the requirements of Building Regulations Document M (Access for the Disabled). As the unit is to be used as a refuge point suitable space must be left to the side of the unit to allow a wheelchair to be parked for using the system

Technical Specification

	VCSHF
Physical	
Height	133mm
Width	133mm
Depth	45mm
Weight	1105g
Material	Zintec, Texture Powder coated RAL3001 Signal Red
Outstation Cables	
Grade	Enhanced
Cable (per Line)	1 off 2 Core (twisted for MICC)
Distance (per leg)	500M soft Skin types, 300M MICC
Monitoring	DC open, short & earth
Indication & Controls	
Status LEDs	1 off Red (flashes for line location, lights solid for call confirmation.)
Call	Press to Call Button
Cancel	Key-switch turn to cancel
Standard Compliances	
EMC	EN55103-1, EN55103-2
LVD	EN60950
Product Family	BS5839-pt9, BS5588-pt8, EN60118-4
Options	
Stainless Steel	Part VCSHF-SS